

Data sheet

# SMC-812 CCL

## CHIPPERTRUCK 6X4/6X6



### SMC-812 CCL CHIPPERTRUCK

The SMC-812 CCL's speciality is its universal range of applications. It does not matter if in narrow mountain areas or urban regions, the SMC-812 CCL performs with the best quality and efficiency. The CCL-model with the crane-cabin mounted on the left side provides a large field of view. Flexible loading without limitations is guaranteed by the hydraulic accelerator attached to the rear of the vehicle. Due to the many available options, the machine can be perfectly adapted to fit the customer's individual needs.

### SMC-812 CHIPPING UNIT

The SMC-812 chipping unit contains the newest available features. Its robust construction and replaceable parts ensure a long service life. Due to versatile setting options in combination with the advanced software, selecting the right quality of the chopped material is made easy. Together with the high performance drive concept, the maximum level of efficiency is achieved.

# TECHNICAL DATA

## Performance

Max. diameter hardwood	60cm
Max. diameter softwood	80cm
Max. throughput	up to 280m <sup>3</sup> /h
Fuel consumption	0.3-0.5 l/m <sup>3</sup>
Chip-size	adjustable G30-G100
Ejection range	up to 35m
Max. power	540 HP (397kW) at 1'450-1'800rpm
Max. Torque at	2'600Nm at 1'000-1'450rpm
Top speed	80km/h

## SMC-812 chipping unit

Infeed size	120 x 80cm
Rotor diameter	950mm
Cutting length	adjustable: 15-45mm
Knives	6pcs. 200mm, 12stk. on request
Infeed table	length 1'800mm hydraulic conveyor belt foldable sidepanels
Infeed	Two bottom feeder roller
Discharge	One large upper feeder roller hydraulic blower discharge

## Dimensions

Wheelbase 1-2, 2-3	3'900mm, 1'350mm
Axle loads	(1) 8'100kg (2+3) 17'800kg
Weight	25'800kg (basic model)
Length	8'230mm
Height	3'970mm
Width	2'550mm
Turning circle	8.75m

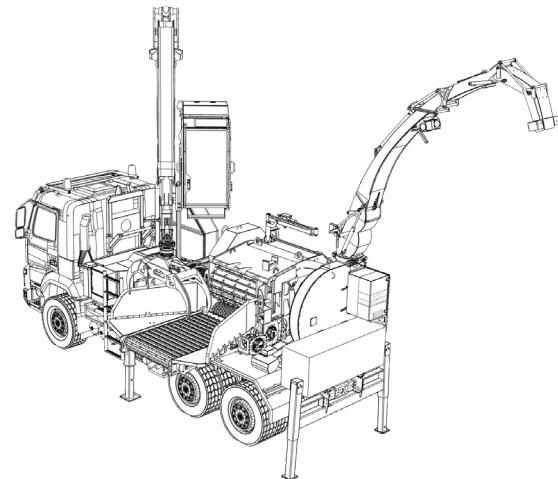

## Options

- 6x6
- Driving from work seat \*
- Various tool boxes
- Various screen sizes and cutting length sets
- Screening crane with electric winch
- Various camera and work light options
- Wedge or cone splitting unit
- 4-fold support
- Central lubrication system
- Wüst Trac-system

For all available options please contact the sales department

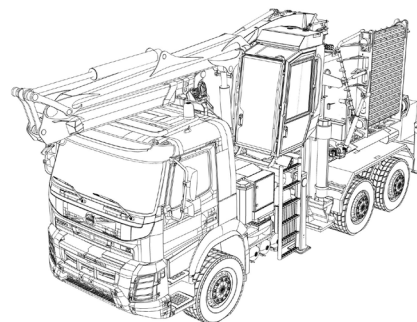
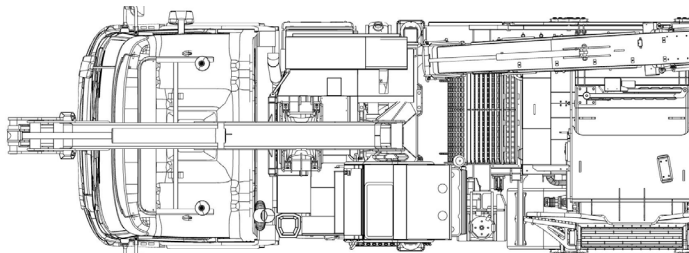
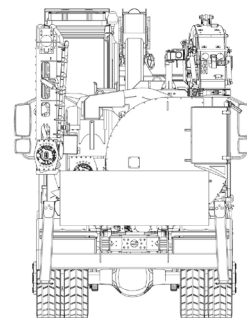
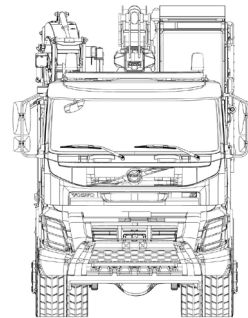
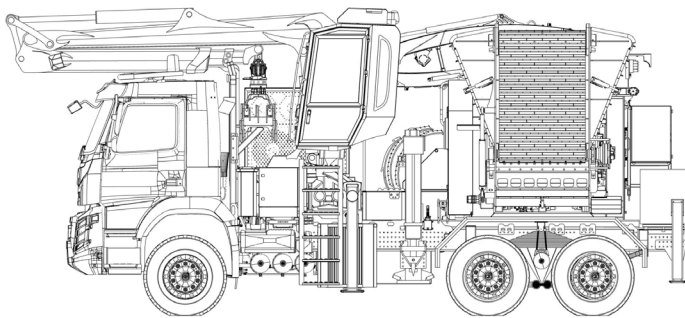

\*Only on private property, no approval for road traffic