

Data sheet

SMC-812 PTO

PTO SHAFT CHIPPER

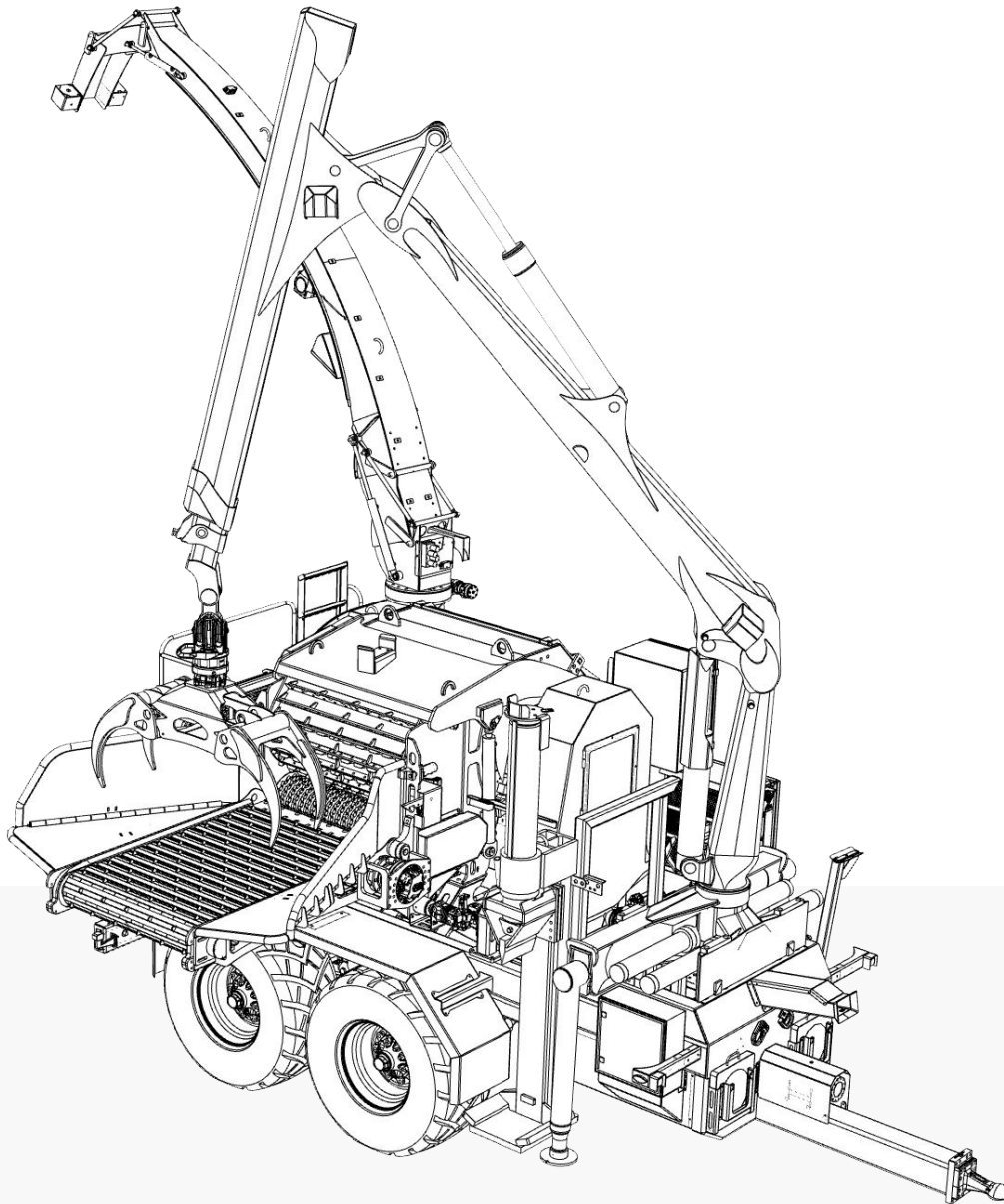

SMC-812 PTO SHAFT CHIPPER

The SMC-812 PTO shaft chipper's speciality is its universal range of applications. With a required drive power of 250 hp, the SMC-812 PTO is the ideal choice for high performance large tractors. The robust design of the undercarriage in combination with the long-life chipping unit the SMC-812 PTO continuously runs in any situation. The many available options allows the machine to be perfectly adapted to the customer's individual needs.

SMC-812 CHIPPING UNIT

The SMC-812 chipping unit contains the newest available features. Its robust construction and replaceable parts ensure a long service life. Due to versatile setting options in combination with the advanced software, selecting the right quality of the chopped material is made easy. Together with the high performance drive concept, the maximum level of efficiency is achieved.

TECHNICAL DATA

Performance

Max. diameter hardwood	60cm
Max. diameter softwood	80cm
Max. throughput	up to 280m ³ /h
Fuel consumption	0.3-0.5 l/m ³
Chip-size	Depending on tractor
Ejection range	adjustable G30-G100
Required power	up to 35m
Top speed	> 250HP
	60km/h

SMC-812 chipping unit

Infeed size	120 x 80cm
Rotor diameter	950mm
Cutting length	adjustable: 15-45mm
Knives	6pcs. 200mm, 12stk. on request
Infeed table	length 1'800mm hydraulic conveyor belt foldable sidepanels
Infeed	Two bottom feeder roller One large upper feeder roller
Discharge	hydraulic blower discharge

Dimensions

Wheelbase	1'310mm
Axle loads	16'500-18'000kg (depending on the option)
Bearing load	2'500kg
Weight	19'000-20'500kg (depending on the option)
Length	6'600mm
Height	3'950mm
Width	2'550mm

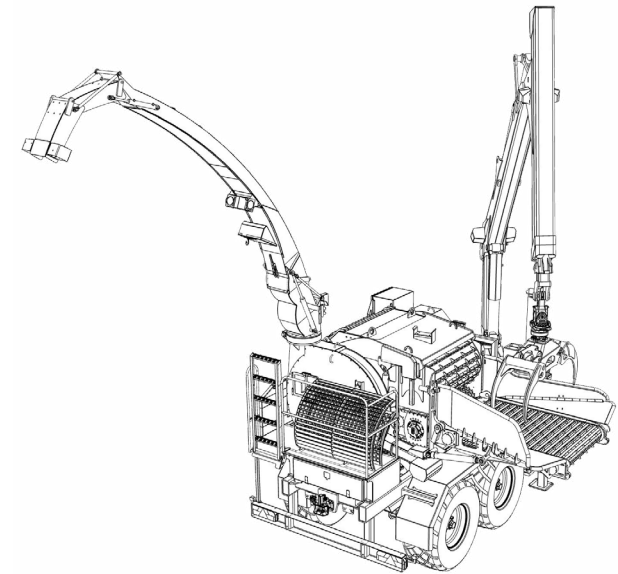

Optionen

- Various types of tyres
- Various tool boxes
- Various screen sizes and cutting length sets
- Screening crane with electric winch
- Various camera and work light options
- Wedge or cone splitting unit
- 4-fold support
- Central lubrication system

For all available options please contact the sales department

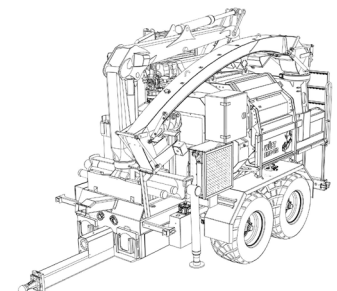
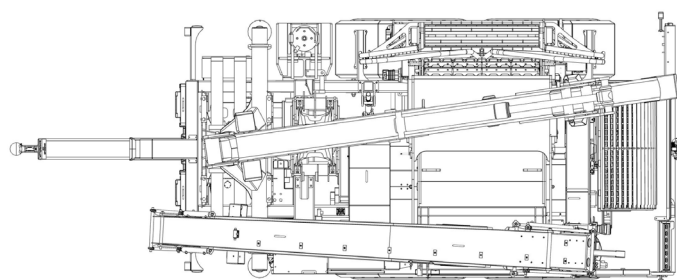
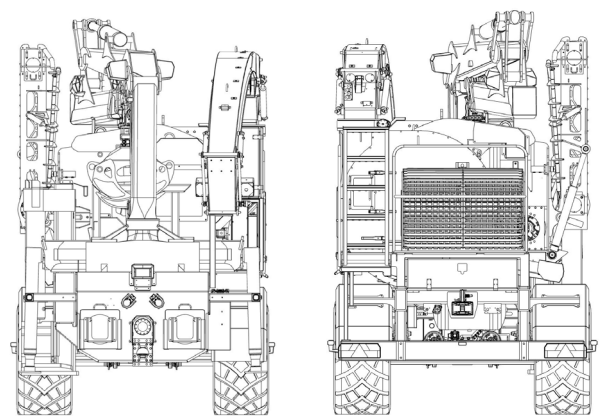
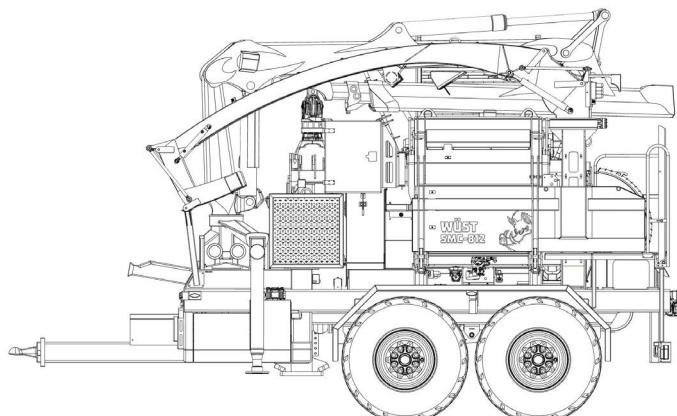

*Only on private property, no approval for road traffic